

END-OF-LINE DEFLAGRATION FLAME ARRESTER

Typ: DAG-A7K-C-IIA-150

Certificate: IBEXU10ATEX2171 X EN ISO 16852 

PIPE CONNECTION		
FLANGED CONNECTION	DN 150 - DIN 2633 - PN16*	
* According to the customers' request DIN 2631 PN6 or DIN 2632 PN10		
MATERIAL OF CASING, CONNECTING FLANGES AND CONNECTION MATERIAL		
ČSN 11 373	DIN 1.0036	S235JRG1
ČSN 17 240	DIN 1.4301	X5CrNi18-10
ČSN 17 348	DIN 1.4571	X6CrNiMoTi17-12-2

MATERIAL QUENCHING ELEMENT	DIN 1.4571 - X6CrNiMoTi17-12-2
SEALING	CS1310 th. 2 mm (expanded graphite)
CORROSION PROTECTION	Zink, Komaxit RAL 2004
ARRESTER WEIGHT	ca. 45 kg
OPERATING TEMPERATURE RANGE	-20 °C... +60 °C
NAMEPLATE	stainless metal sheet
EXPLOSION CLASS	IIA

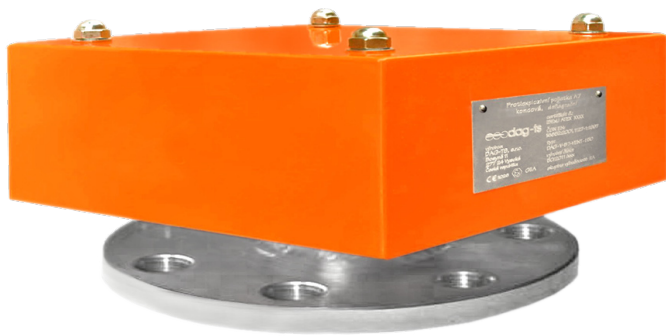

SafExty NExus®

FLAME ARRESTER'S PRESSURE DROP

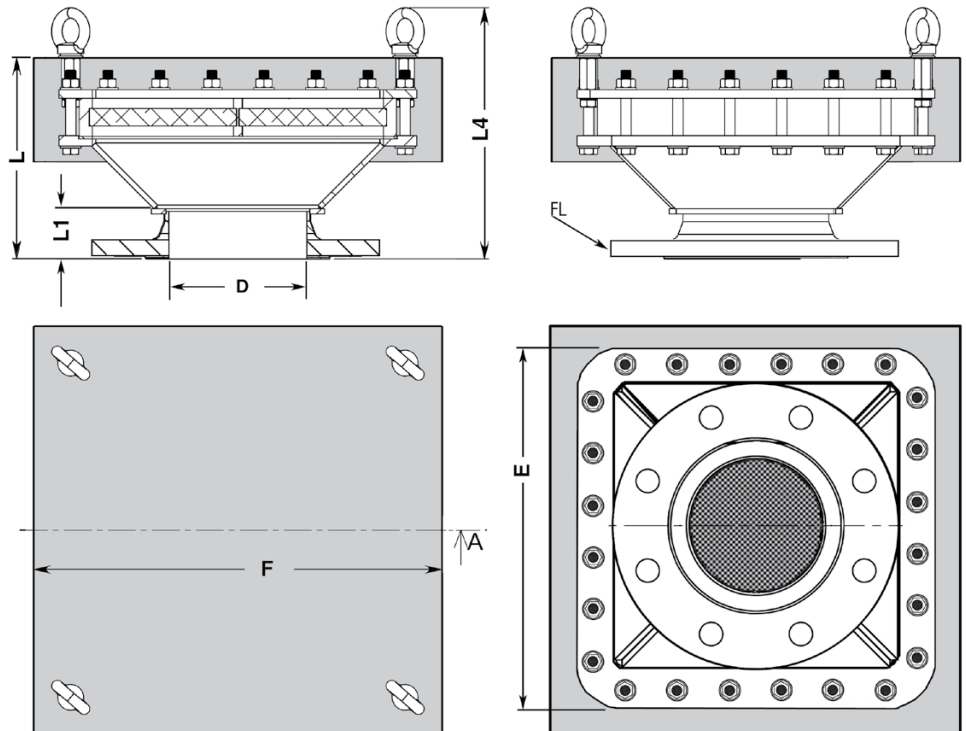
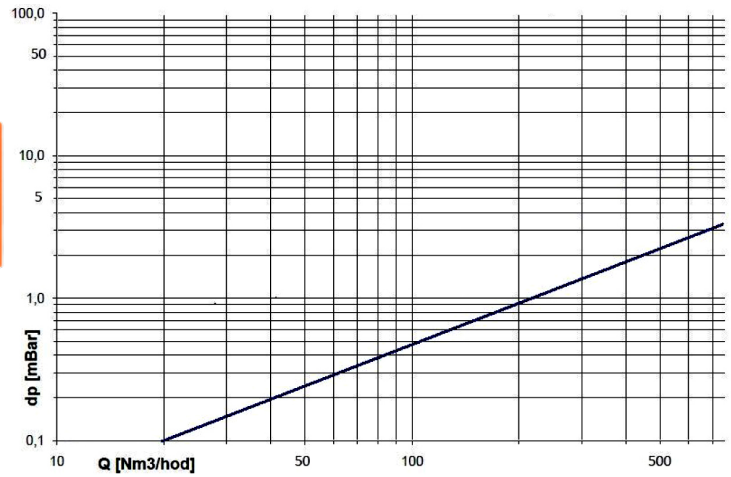

ROZMĚRY - ABMESSUNGEN DIMENSIONS		
D	DN	150
E	[mm]	415
F	[mm]	472
L	[mm]	233
L1	[mm]	58
L4	[mm]	290
FL	DIN 2633	PN16

Technické změny vyhrazeny -
Technische Änderungen vorbehalten -
Specifications subject to change without notice